

Case Study

The Edge, Amsterdam

Commercial

Shape
your vision

A Beautiful, Intelligent and Unique Building

The world's most sustainable office building with a sustainability score of 98.36%, Outstanding certification and a prestigious BREEAM award to its name stands in Amsterdam.

Recognised as the 'most sustainable office building in the world', it is a beautiful, intelligent and unique building.

From the 15-storey-high atrium, allowing sufficient light into the building, to the sloping roof that pierces the skyline, The Edge makes a global impression. The most advanced techniques were used during construction. Among other things, 3D printing technology was applied in the Novastruct façade.

For the BREEAM Outstanding score, everything was considered, from climate control to a light intensity app and from solar collectors to beehives on the roof.

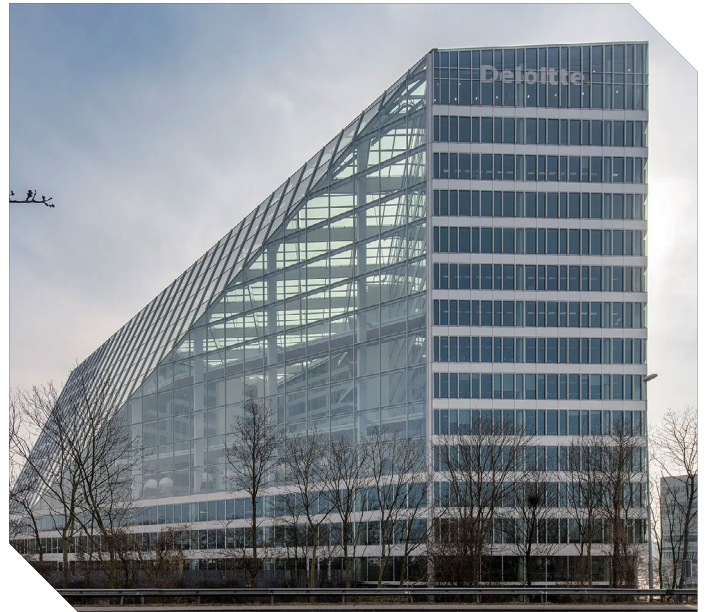

“The world’s most sustainable office building”



The Edge is not only an experience to savour as a visitor, above all it is a sustainable environment that makes the employee more satisfied and productive.

During the design and construction of the 40,000m² pentagonal office building with angled façade, consideration was given to sustainability, comfort, productivity of the users and naturally future-proofing.

The façade plays an important role at The Edge. For example, the transparent atrium on the north side enables climate control, and the solar collectors on the sun side are integrated into the façade.

Building: The Edge
Location: Amsterdam
Architect: PLP Architecture/OZ architect
Main Contractor: G&S Bouw
Installer: Rollocate

Active Energy Concepts

At the beginning of the design, the target was an Excellent certification, but when it became clear during the process that more was possible, the designers focused on an Outstanding certification.

The Edge is one of the largest buildings in the world to achieve an Outstanding certificate from BREEAM. Cees den Ouden, senior project manager at OeverZaaijer, believes that the achievement in this area, in addition to the structural approach, is also thanks to the installation technology. Active energy concepts were used in The Edge, such as thermal energy storage (TES), a heat pump system connected to district heating, a PV installation on the south façade and the roof, consisting of hundreds of solar panels, and a climate ceiling in the building that provides both cooling and heating. However, these energy concepts only come fully into their own if the outer shell of the building is highly insulating.

Thanks to the enormous angled glass façade, The Edge is a striking appearance on the Zuidas in Amsterdam. The glass atrium of approximately 3,000 m², constructed from the ground to the top, is a very eye-catching feature of the office building. The glass atrium removes ventilation air from all 15 floors, the façade regulates sufficient daylight entry and heat supply takes place through the space. Especially the upper half of the façade posed a challenge, because nothing in the façade is straight.

“The façade has a large surface area with large spans and the necessary connections,” explains Den Ouden. ‘In addition, the roof not only slopes backwards, but also contains an angle.’

There is also always movement in the façade due to temperature changes, so the tolerances had to be properly integrated.

The Novastruct products applied contribute to the BREEAM score in various ways, covering the largest part of the building façade and providing excellent insulation, helping to reduce energy loss.

Novastruct’s range of solutions also contributes to the ‘health and well-being’ category of BREEAM by enabling optimal daylight entry and transparency in the building.

And considering the fact that Novastruct supplies only aluminium products, a sustainable and highly efficient building material, the project also received points in the ‘materials’ category.

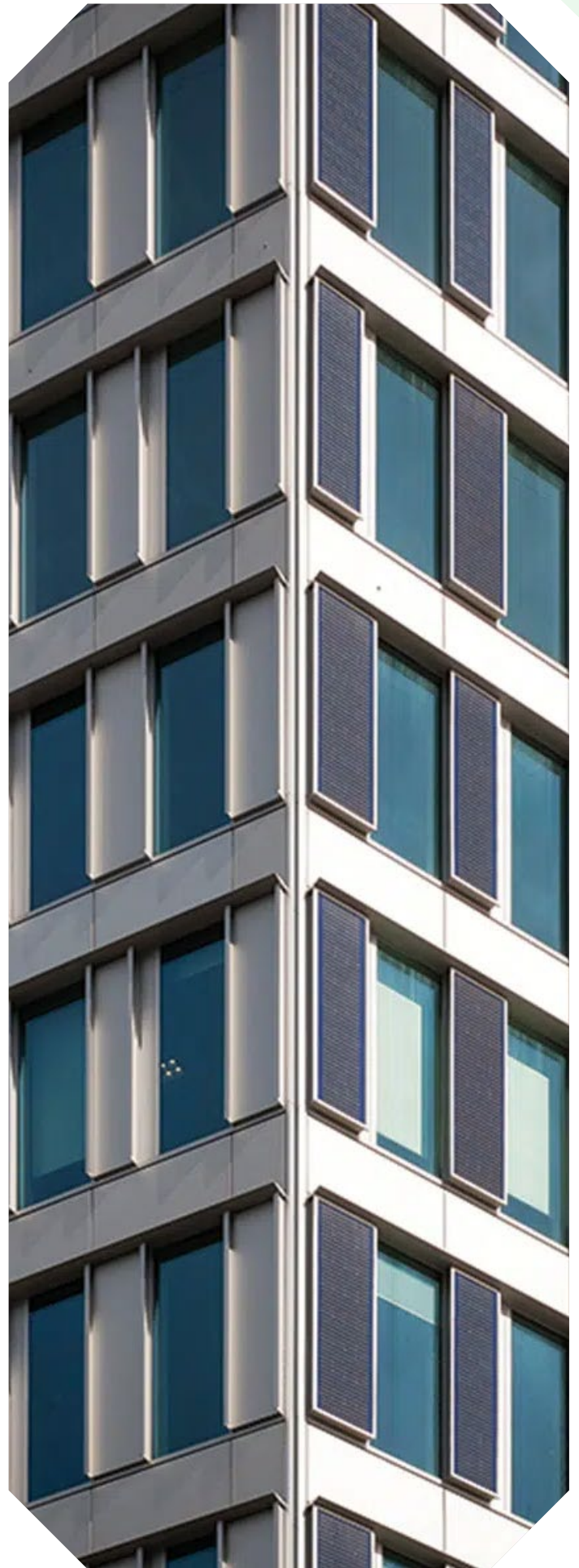

Meeting Design Challenges

The sloping, angled façade of The Edge proved to be quite a technical challenge. A design with different angles alone would already be difficult. But in this project, the architect also wanted to see perfect vertical lines when looking at the building.

For this unique project, multiple complicated processes were required to develop, install and make everything work perfectly. Every product was specially developed for this project to meet the requirements and needs.

Novastruct's ability to create custom-made products ensured that it was top-of-mind with the architects working on this project. With its long history of proven engineering and custom-made solutions, Novastruct was asked to supply systems and solutions for the building.

Façade construction company Rollocate from Staphorst worked together with Novastruct and installed these products and solutions.

The Novastruct products incorporated into The Edge included the RT 72 Reflex window system and FSX 100 curtain walling.

For the wedge-shaped section of the façade that slopes backwards, a special project solution was created by Novastruct. Martijn Bergsma, project engineer, explains: "To properly drain rainwater, it was necessary to adjust the contours of the profiles. We gave the profiles the same angle as the roof, allowing the water management to remain on the horizontal plane.

'The connections and sealing of the sloping façade surfaces were so complex that conventional seals were insufficient,' explains Bergsma. "This was solved by applying innovative 3D printing technology."

After years of research and collaboration with Delft University of Technology to apply 3D printing in façades, a 3D printed component was actually implemented in practice in The Edge.

The seals were drawn based on 3D models and subsequently printed with high dimensional tolerance and assembled in the façade.

'This technique guarantees high wind and water tightness and simultaneously provides optimisation in the production process.'



A Special Opening Element

That the architectural requirements at The Edge required a number of adjustments is acknowledged by Richard Meyer, field sales manager at Novastruct.

“In this case, the adjustments and tolerances were so complex that we had to develop special wooden moulds in order to insulate the profiles.”

That adjustments are needed to aluminium elements is nothing unusual. According to Meyer, that happens almost daily, but in this case the process required close attention.

Not only because the spans are so large, but also because there are high requirements regarding energy savings.

“That also applies to the window strips on the office floors,” Meyer clarifies. “There, elongated, very narrow opening elements have been installed in the façade, built up from a single aluminium profile. Hundreds of heat flow calculations were required in order to optimise the design of those windows and the atrium.”

Ultimately, designing, developing and producing The Edge took approximately three years. An example of Novastruct’s dedication to providing intelligent solutions that deliver high performance, superior thermal efficiency and beautiful aesthetics, making best-in-class design and performance possibilities a reality.

“We are very proud to have been able to collaborate on such a prestigious project and that with our knowledge and innovation we have been able to contribute to this beautiful structure,” said Meyer.



Product Specification Highlights

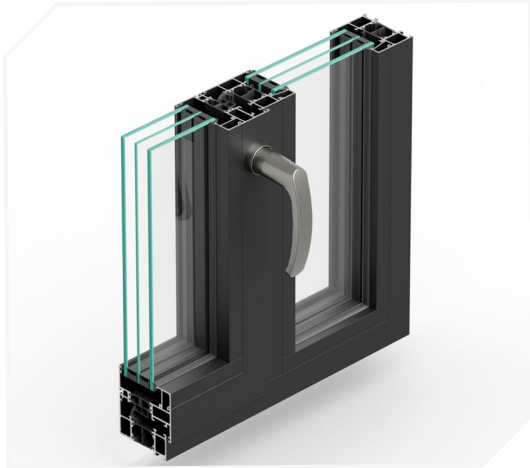

**RT 72 Reflex Aluminium
Open-In Window**

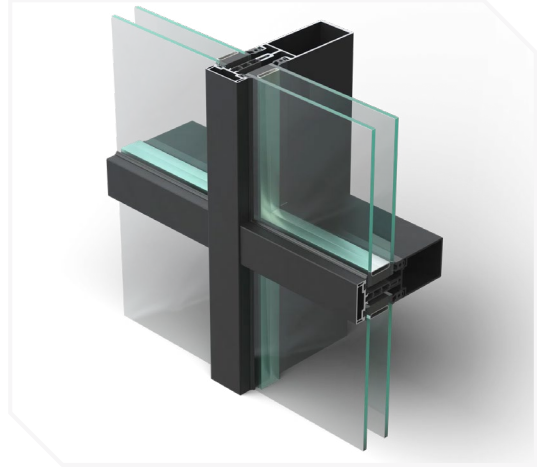

FSX 100 Curtain Wall System

Project Photos: Dirk Verwoerd

Novastruct UK

Astmoor Road
Astmoor Industrial Estate
Runcorn, Cheshire
WA7 1QQ
United Kingdom

Tel.: + 44 (0)1928 502500
Mail: Sales.UK@novastructeurope.com

www.novastructeurope.co.uk

**Shape
your vision**

 **nova
struct®**