

Case Study

St Sidwell's Point Leisure Centre,
Exeter

Arts & Leisure

ST SIDWELL'S POINT

Shape
your vision

The UK's First Passive House Leisure Centre

With sustainable and responsible design being at the forefront of modern architecture, Gale & Snowden Architects chose Novastruct aluminium glazing systems as part of the energy efficient design to transform St Sidwell's Point into the UK's first Passive House leisure centre.

Located in Exeter, Devon, this 6,700m² project centred around the replacement of an ageing leisure centre swimming pool with an eight-lane national/county-standard pool and four-lane learner pool, both featuring movable floors.



“Energy efficient design”

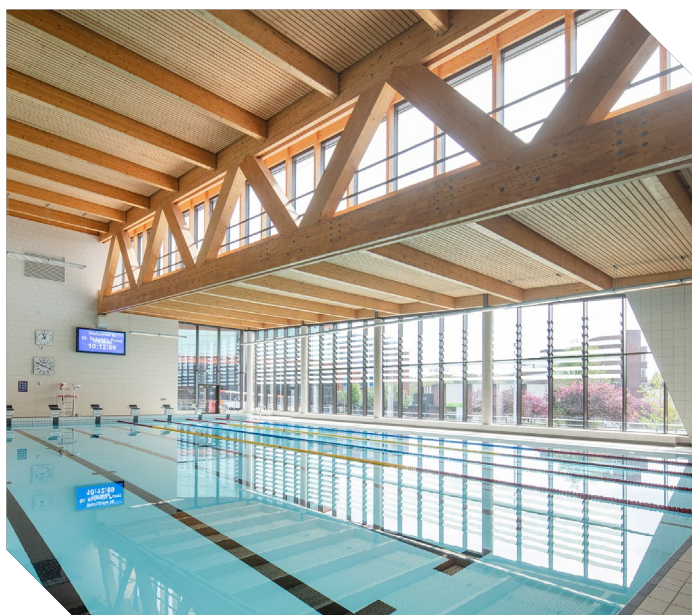

One considerable façade challenge was to achieve an average 0.8 W/ m²K and a 0.4 m³/h/m² @ 50 pascals air leakage which exceeds the current building regulations.

For the main glazed areas, two types of curtain walling and three types of doors were specified, as well as high performance windows and brise soleil. All were installed by Novastruct approved specialist sub-contractor AB Glass on behalf of the main contractor Kier Construction.

Building: St Sidwell's Point Leisure Centre
Location: Exeter
Architect: Gale & Snowden
Main Contractor: Kier Construction
Installer: AB Glass

Distinctive Envelope

Passive House-certified FSX 100 HI capped curtain walling was used to create the distinctive building envelope and complement some internal locations. These were complemented by Novastruct's DSX 190 TB external entrance doors.

Benefits of the Passive House design include a 70% saving on energy costs when compared to a current 'good practice' leisure centre facility, a 50% reduction in water use, outstanding internal water and air quality, excellent daylight levels and lower maintenance costs due to a high-quality building fabric.



Innovative Project

Nigel Harvey, Managing Director of AB Glass, said: "This is an innovative project that we have been very excited to be involved in. The environmental credentials of this building are such that we believe some of the standards and skills we have implemented here will be in high demand in the future as many more buildings look to emulate what we see here."

As well as state-of-the-art swimming pools, new dry sports facilities include a gym, café and crèche, together with health and spa amenities. The flagship leisure centre in Exeter City Council's £330 million city centre regeneration masterplan is expected to attract more than 500,000 visitors a year.

St Sidwell's Point Leisure Centre has won five prestigious awards: Net Zero, Building Project of the Year and Winner of Winners at the South West Constructing Excellence Awards, also, Most Sustainable Building and RCI Project of the Year at the Facade Awards UK.



Product Specification Highlights

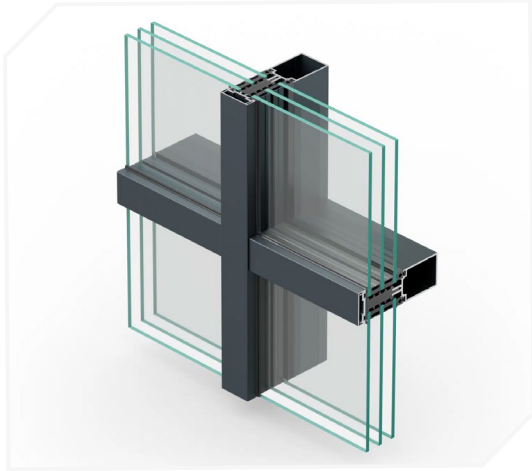

FSX 100 HI Curtain Wall System



DSX 190 TB Door

Novastruct UK

Astmoor Road
Astmoor Industrial Estate
Runcorn, Cheshire
WA7 1QQ
United Kingdom

Tel.: + 44 (0)1928 502500
Mail: Sales.UK@novastructeurope.com

www.novastructeurope.co.uk

**Shape
your vision**

 **nova
struct®**