

Case Study

Primrose Hill, London

Residential

Shape
your vision

An Enviably Neighbourhood

One of the most significant challenges architects can face is regenerating an area full of personality, but in desperate need of renovation. The challenge can be even more demanding if the project involves changing the purpose of the site. But that's precisely what the architects in charge of the Primrose Hill project in London, had to face.

With a project value of approximately £16m this project required a highly sensitive design solution to address a complicated urban context involving 28 neighbouring residential and commercial properties.

The transformation envisioned by PKS Architects, and developed by main contractor Knight Harwood, involved converting some of the buildings into high-quality apartments and high-specification offices using Novastruct's solutions.



“Regenerating an area full of personality”



The task was immense and involved six neighbouring commercial properties. The goal was achieved using multiple high-performance Novastruct products.

Building: Primrose Hill
Location: London
Architect: PKS Architects
Main Contractor: Knight Harwood
Installer: JPJ Installations Ltd

Thorough Specification

Through site-specific technical visits and studies, Novastruct specified and costed various façade packages and options.

The lack of natural light was one of the many problems that needed to be rectified. It was solved using Novastruct's FSX 100 sloped rooflights. Additionally, GT 70 S windows were specified to replicate the building's original steel windows to compliment the building aesthetics.

For the curtain wall specification, the natural choice was FSX 100 SSG, since it has smooth and seamless glass-to-glass joints without external capping.



Award Winner

The resulting specification helps to enhance the aesthetics of the building façade and increase the energy performance of the building whilst meeting the cost requirements of the build with Novastruct's market-leading product range.

Shortlisted in the BREEAM Awards, this development sustainably refurbishes and reimagines a group of six buildings to create 3,500m² of high specification office space and four new luxury flats.

The impressive results haven't gone unnoticed. The Primrose Hill project won the GGP's Best Commercial Installation, by Novastruct's customer and specialist facade subcontractor, JPJ Installations Ltd.



Product Specification Highlights

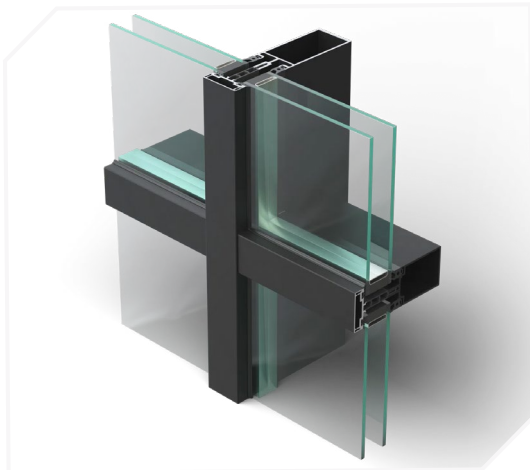

FSX 100 50mm Curtain Wall System

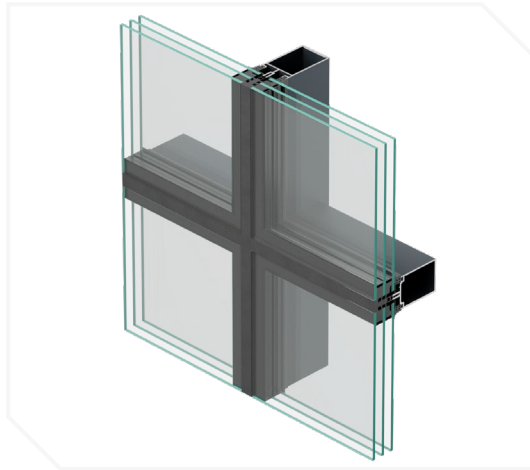

FSX 100 SSG Curtain Wall System

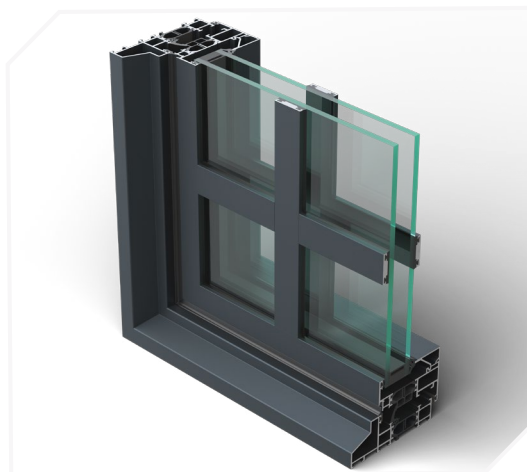

GT70 S Open-In Window

Novastruct UK

Astmoor Road
Astmoor Industrial Estate
Runcorn, Cheshire
WA7 1QQ
United Kingdom

Tel.: + 44 (0)1928 502500
Mail: Sales.UK@novastructeurope.com

www.novastructeurope.co.uk

Shape
your vision

 **nova
struct**