

# Case Study

Eclipse Leisure Centre,  
Staines-upon-Thames

Arts & Leisure

Shape  
your vision

# Passive House Award Winner

The Eclipse Leisure Centre in Staines-upon-Thames is the UK's largest wet and dry leisure centre to achieve Passive House certification. Spelthorne Borough Council's ambitious goal was to create one of the world's most sustainable leisure centres.

The council's vision was transformed into reality by GT3 Architects, Gale & Snowden Architects Ltd and built by Willmott Dixon.

Eclipse consumes 60% less energy than traditional leisure facilities, setting a new standard for sustainability in the sector, significantly reducing its environmental impact.



“One of the world’s most  
sustainable leisure centres”



This state-of-the-art facility boasts an impressive range of amenities, including a 25m main pool, learner pool, spa, gym, Clip 'n Climb with 14 climbing experiences, 6-court sports hall with LED markings and artificial rooftop football pitches.

Building: Spelthorne Leisure Centre  
Location: Staines-upon-Thames  
Architect: GT3 Architects/Gale & Snowden  
Main Contractor: Willmott Dixon  
Installer: Leay Ltd

# Meeting Project Targets

Recognised for its outstanding environmental efficiency and sustainability performance credentials, Eclipse Leisure Centre is one of the world's largest Passive House certified leisure centres. Novastruct played a crucial role in achieving these sustainability goals.

System selection was driven by stringent U-value and air tightness targets. Air tightness was particularly challenging to achieve, especially for the doors. This led to the specification of high performing, energy efficient doors, developed in collaboration between our UK & European design teams, for which a project-specific threshold detail was developed. Active communication makes these types of solutions possible for our customers, pushing the boundaries to deliver a project exceeding expectations and driving industry standards forward.

The following Kawneer solutions were selected for the project:

- FSX 100 HI: Enhanced thermal performance curtain wall system.
- Windows & Doors: High performing, energy-efficient window and door combination.

The Novastruct systems were fabricated and installed by LEAY LTD, who have been collaborating with us for over half a century. Their knowledge and expertise of our systems and Passive House certified staff helped to ensure the ambitious performance targets were attained.

David Pettett, Pre-Construction Manager at LEAY LTD added: "Outside of the domestic market, Passive House, certainly in England, is a relatively new concept to achieve. With the help of Novastruct, along with some extensive U value and fRsi calculations, the performance required was realised.

"In order to achieve such a high level of thermal performance, airtightness and robust detailing requires a collaborative approach and coordination between subcontractors and the supply chain. Early engagement during design was key to the project's success.

"This could not have been achieved without a diligent installation, with a huge emphasis on quality. Furthermore, whilst this was our first Passive House project, with the help and collaboration with Willmott Dixon, Gale and Snowdon, GT3 Architects, Novastruct and our wider supply chain, we are now able to say, 'we did it!'"

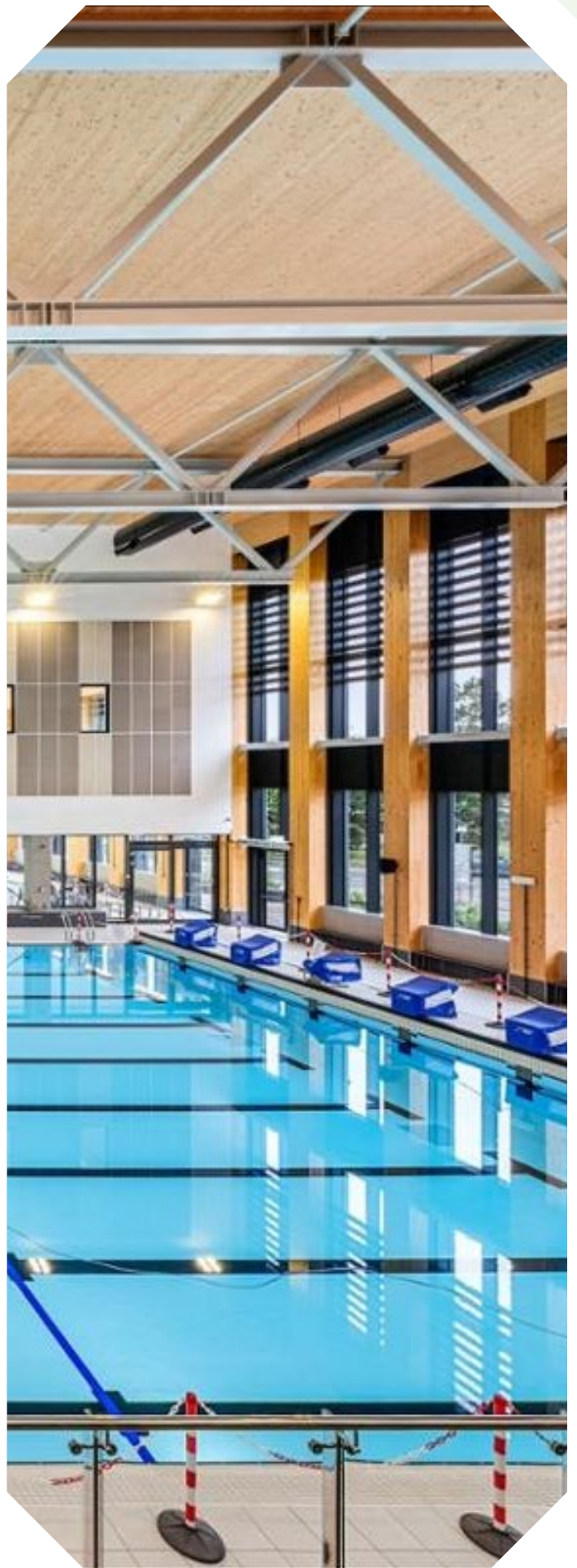

# Innovative Technologies

Eclipse Leisure Centre's highly praised design and functionality was recognised with a Silver Award at the iESE Public Sector Transformation Awards, acknowledging Spelthorne Borough Council's commitment to innovative technologies.

Leader of Spelthorne Borough Council, Cllr Joanne Sexton, stated: "We are very proud of everything that has been achieved and the fact we have delivered one of the most advanced and energy-efficient centres in the world."

Mark Gowdridge, Director at GT3 Architects, added: "As one of the UK's first leisure centres designed to Passive House standards, Eclipse has shown us the future of leisure in terms of reduced energy waste and running costs."

Richard Poulter, Managing Director at Willmott Dixon Construction South, commented: "This state-of-the-art facility reflects our commitment to building high-quality, energy-efficient projects that truly benefit the

community. The Eclipse Centre sets a new benchmark for sustainability in leisure construction."

The building stands as a testament to what can be achieved through collaboration, forward-thinking design, and a steadfast commitment to sustainability.

Is your next project looking for a tailor-made solution such as this? Contact our team today.



# Product Specification Highlights

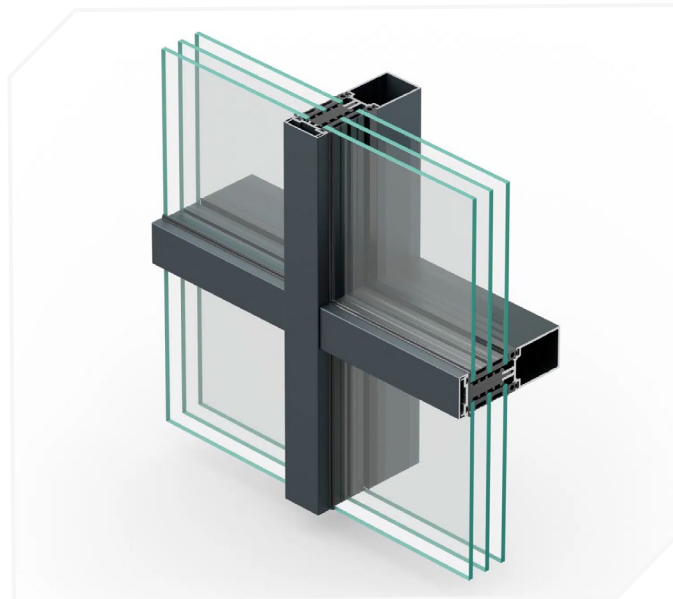

FSX 100 HI Curtain Wall System

**Novastruct UK**

Astmoor Road  
Astmoor Industrial Estate  
Runcorn, Cheshire  
WA7 1QQ  
United Kingdom

Tel.: + 44 (0)1928 502500  
Mail: Sales.UK@novastructeurope.com

[www.novastructeurope.co.uk](http://www.novastructeurope.co.uk)

Shape  
your vision

 nova  
struct®